

CORRECTION

Open Access



Correction to: Urgent need hybrid production - what COVID-19 can teach us about dislocated production through 3d-printing and the maker scene

Sascha Hartig^{1*}, Sven Duda² and Lennart Hildebrandt¹

Correction to: *3D Print Med* 6, 37 (2020)
<https://doi.org/10.1186/s41205-020-00090-5>

In the original publication [1] the figures and captions were incorrectly matched during an error in the publication process. This only affected the web publication and did not affect the PDF-publication. In this correction article the correct figure & caption combinations are published. The original article has been updated.

Author details

¹Helmut Schmidt University, Institute of Production Engineering, Holstenhofweg 85, 22043 Hamburg, Germany. ²Hospital of the German Armed Forces, Department of Neurosurgery, Lange Strae 38, 26655 Westerstede, Germany.

Published online: 08 February 2021

Reference

1. Hartig S, Duda S, Hildebrandt L. Urgent need hybrid production - what COVID-19 can teach us about dislocated production through 3d-printing and the maker scene. *3D Print Med*. 2020;6:37. <https://doi.org/10.1186/s41205-020-00090-5>.

The original article can be found online at <https://doi.org/10.1186/s41205-020-00090-5>.

* Correspondence: sascha.hartig@hsu-hh.de

¹Helmut Schmidt University, Institute of Production Engineering, Holstenhofweg 85, 22043 Hamburg, Germany
Full list of author information is available at the end of the article



© The Author(s). 2021 **Open Access** This article is licensed under a Creative Commons Attribution 4.0 International License, which permits use, sharing, adaptation, distribution and reproduction in any medium or format, as long as you give appropriate credit to the original author(s) and the source, provide a link to the Creative Commons licence, and indicate if changes were made. The images or other third party material in this article are included in the article's Creative Commons licence, unless indicated otherwise in a credit line to the material. If material is not included in the article's Creative Commons licence and your intended use is not permitted by statutory regulation or exceeds the permitted use, you will need to obtain permission directly from the copyright holder. To view a copy of this licence, visit <http://creativecommons.org/licenses/by/4.0/>. The Creative Commons Public Domain Dedication waiver (<http://creativecommons.org/publicdomain/zero/1.0/>) applies to the data made available in this article, unless otherwise stated in a credit line to the data.

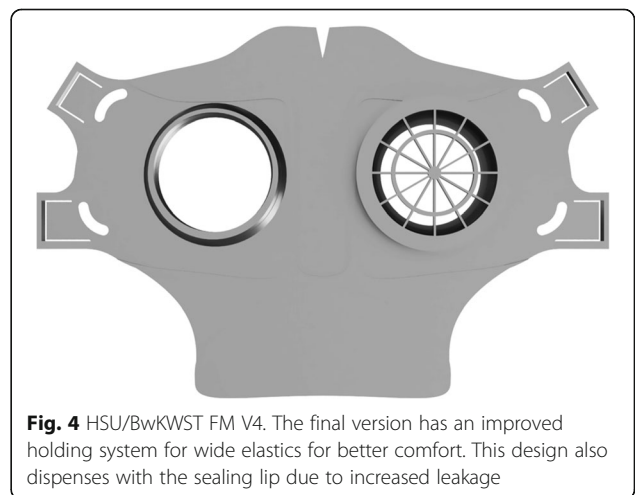
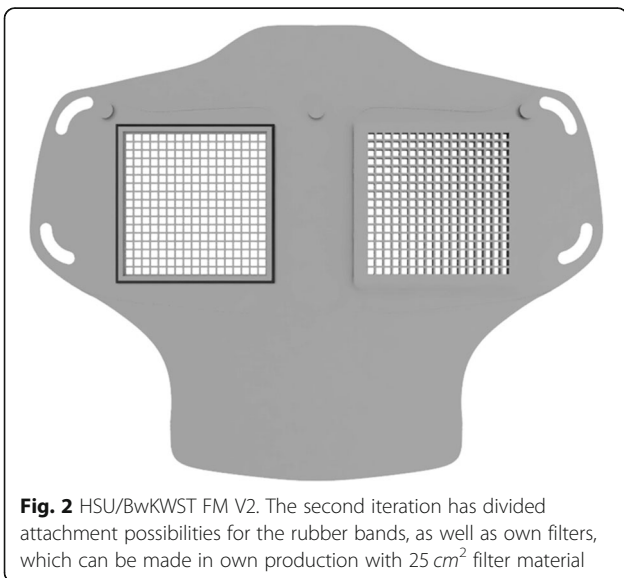
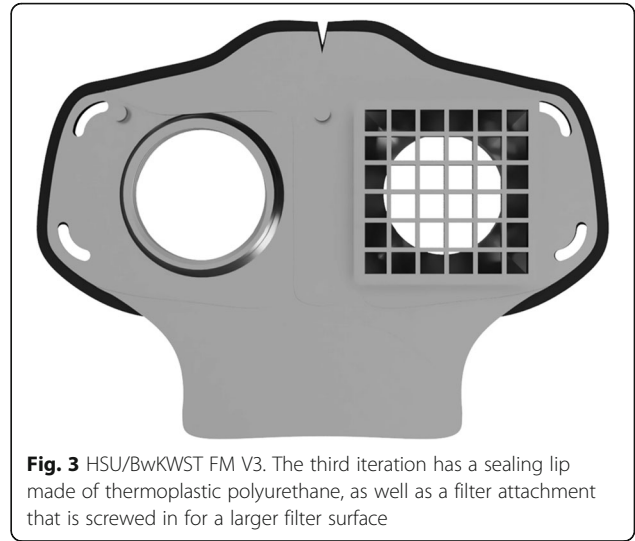
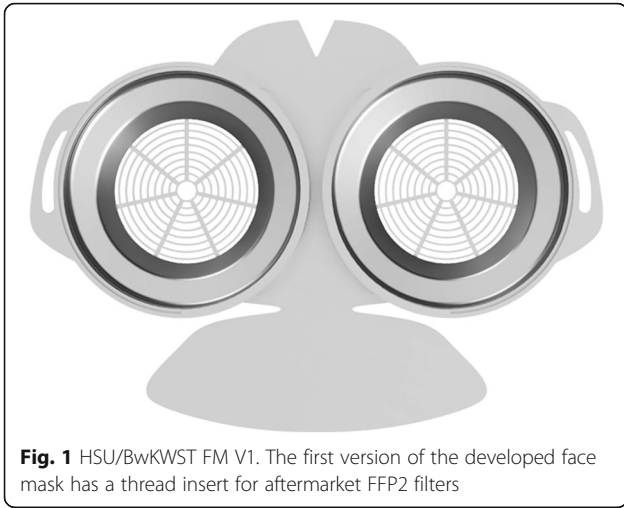



Fig. 5 Side view HSU/BwKWST FM V3. Thermoformed face mask in version three with elastics and TPU sealing lip, black



Fig. 6 Printer Farm at CTC GmbH (an AIRBUS Company) in Stade, Germany. The printer farm at the CTC GmbH in Stade is a good example how a print farm can be build and what features can be implemented

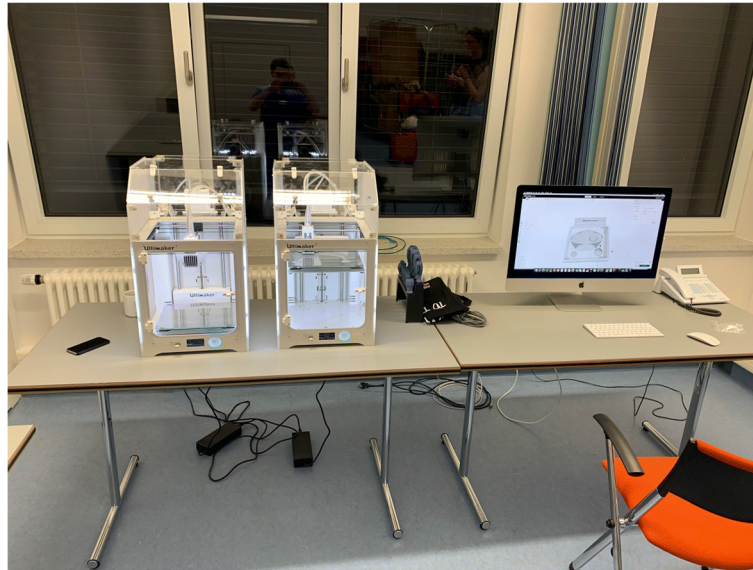

Fig. 7 Early test setup. This was used for experiments, development and in-house production at the German Armed Forces Hospital in Westerstede

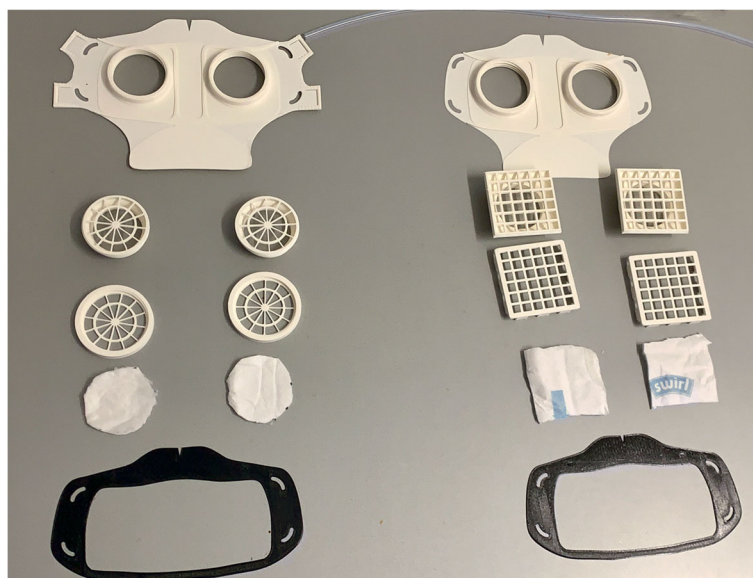

Fig. 8 Comparison of all parts HSU/BwKWST FM V4 left and V3 right. From top to bottom the following parts are shown: PLA Mask body, PLA two-piece filter inserts, temporary filter mat cuttings, TPU sealing lip

